

SET-2**Series SGN**कोड नं. **57/2**
Code No.रोल नं.

--	--	--	--	--	--	--

Roll No.

परीक्षार्थी कोड को उत्तर-पुस्तिका के मुख-पृष्ठ पर अवश्य लिखें ।

Candidates must write the Code on the title page of the answer-book.

- कृपया जाँच कर लें कि इस प्रश्न-पत्र में मुद्रित पृष्ठ **11** हैं ।
- प्रश्न-पत्र में दाहिने हाथ की ओर दिए गए कोड नम्बर को छात्र उत्तर-पुस्तिका के मुख-पृष्ठ पर लिखें ।
- कृपया जाँच कर लें कि इस प्रश्न-पत्र में **26** प्रश्न हैं ।
- कृपया प्रश्न का उत्तर लिखना शुरू करने से पहले, प्रश्न का क्रमांक अवश्य लिखें ।
- इस प्रश्न-पत्र को पढ़ने के लिए 15 मिनट का समय दिया गया है । प्रश्न-पत्र का वितरण पूर्वाह्न में 10.15 बजे किया जाएगा । 10.15 बजे से 10.30 बजे तक छात्र केवल प्रश्न-पत्र को पढ़ेंगे और इस अवधि के दौरान वे उत्तर-पुस्तिका पर कोई उत्तर नहीं लिखेंगे ।
- Please check that this question paper contains **11** printed pages.
- Code number given on the right hand side of the question paper should be written on the title page of the answer-book by the candidate.
- Please check that this question paper contains **26** questions.
- **Please write down the Serial Number of the question before attempting it.**
- 15 minute time has been allotted to read this question paper. The question paper will be distributed at 10.15 a.m. From 10.15 a.m. to 10.30 a.m., the students will read the question paper only and will not write any answer on the answer-book during this period.

जीव विज्ञान (सैद्धान्तिक)

BIOLOGY (Theory)

निर्धारित समय : 3 घण्टे

Time allowed : 3 hours

अधिकतम अंक : 70

Maximum Marks : 70



सामान्य निर्देश :

- (i) प्रश्न-पत्र में पाँच खण्डों में 26 प्रश्न दिए गए हैं। सभी प्रश्न अनिवार्य हैं।
- (ii) खण्ड A में प्रश्न संख्या 1 से 5 अति लघु-उत्तरीय प्रश्न हैं, प्रत्येक प्रश्न 1 अंक का है।
- (iii) खण्ड B में प्रश्न संख्या 6 से 10 लघु-उत्तरीय प्रश्न प्रकार I के हैं, प्रत्येक प्रश्न 2 अंकों का है।
- (iv) खण्ड C में प्रश्न संख्या 11 से 22 लघु-उत्तरीय प्रश्न प्रकार II के हैं, प्रत्येक प्रश्न 3 अंकों का है।
- (v) खण्ड D में प्रश्न संख्या 23 मूल्य आधारित प्रश्न 4 अंकों का है।
- (vi) खण्ड E में प्रश्न संख्या 24 से 26 दीर्घ-उत्तरीय प्रश्न हैं, प्रत्येक प्रश्न 5 अंकों का है।
- (vii) प्रश्न-पत्र में समग्र पर कोई विकल्प नहीं है, फिर भी 2 अंकों वाले एक प्रश्न में, 3 अंकों वाले एक प्रश्न में और 5 अंकों वाले सभी तीनों प्रश्नों में भीतरी चयन-विकल्प दिए गए हैं। प्रत्येक परीक्षार्थी को ऐसे प्रश्नों के दो विकल्पों में से कोई एक प्रश्न हल करना है।

General Instructions :

- (i) There are a total of 26 questions and five sections in the question paper. All questions are compulsory.
- (ii) Section A contains questions number 1 to 5, very short-answer type questions of 1 mark each.
- (iii) Section B contains questions number 6 to 10, short-answer type I questions of 2 marks each.
- (iv) Section C contains questions number 11 to 22, short-answer type II questions of 3 marks each.
- (v) Section D contains question number 23, value based question of 4 marks.
- (vi) Section E contains questions number 24 to 26, long-answer type questions of 5 marks each.
- (vii) There is no overall choice in the question paper, however, an internal choice is provided in one question of 2 marks, one question of 3 marks and all the three questions of 5 marks. In these questions, an examinee is to attempt any one of the two given alternatives.



खण्ड A

SECTION A

1. प्राक्-इंसुलिन में होने वाले उस रासायनिक परिवर्तन का उल्लेख कीजिए जिसके द्वारा वह परिपक्व इंसुलिन की तरह कार्य करने में सक्षम हो जाता है । 1

Mention the chemical change that proinsulin undergoes, to be able to act as mature insulin.

2. निम्नलिखित के नाम लिखिए : 1

(a) 15 मिलियन वर्ष पूर्व वनमानुष (ऐप) के समान प्राइमेट

(b) 2 मिलियन वर्ष पूर्व पूर्वी अफ्रीका के घास-स्थलों में रहने वाले प्राइमेट

Write the names of the following :

(a) A 15 *mya* primate that was ape-like

(b) A 2 *mya* primate that lived in East African grasslands

3. दो रोगों के नाम लिखिए जिनका प्रसार एडीज़ मच्छरों के उन्मूलन के द्वारा नियंत्रित किया जा सकता है । 1

Name two diseases whose spread can be controlled by the eradication of *Aedes* mosquitoes.

4. मानव में साइटोकाइन रोध मानव में किस प्रकार सहज प्रतिरक्षा प्रदान करते हैं ? 1

How do cytokine barriers provide innate immunity in humans ?

5. वह दोहरे उद्देश्य लिखिए जिनकी बहुलकीकरण में पूर्ति डीऑक्सीराइबोन्यूक्लियोसाइड ट्राइफॉस्फेट करते हैं । 1

Write the dual purpose served by Deoxyribonucleoside triphosphates in polymerisation.



खण्ड B

SECTION B

6. (a) हिरोइन ड्रग के स्रोत पौधे का नाम लिखिए । यह पौधे से किस प्रकार प्राप्त की जाती है ?
- (b) मानव शरीर पर हिरोइन के प्रभावों को लिखिए । 2
- (a) Name the source plant of heroin drug. How is it obtained from the plant ?
- (b) Write the effects of heroin on the human body.
7. आपको अधिक उपज वाली टमाटर की एक नई किस्म प्राप्त हुई है । उस तकनीक का नाम लिखिए जिसके द्वारा टमाटर फ़सल की भावी पीढ़ियों की बड़ी समष्टियों में वांछित लक्षणों की निरंतरता बनाए रखने को सुनिश्चित किया जा सके । इस विधि की व्याख्या भी कीजिए । 2
- You have obtained a high yielding variety of tomato. Name and explain the procedure that ensures retention of the desired characteristics repeatedly in large populations of future generations of the tomato crop.
8. ऐसा माना जाता है कि किसी समष्टि में एक जीन की ऐलील आवृत्तियाँ पीढ़ी दर पीढ़ी एकसमान रहती हैं । हार्डी-वेनबर्ग ने बीजगणितीय समीकरण की सहायता से इसकी व्याख्या किस प्रकार की ? 2

अथवा

यद्यपि असीमकेन्द्रकी कोशिका में स्पष्ट केन्द्रक नहीं होता, फिर भी डी.एन.ए. पूरी कोशिका में फैला नहीं होता । व्याख्या कीजिए । 2

With the help of an algebraic equation, how did Hardy-Weinberg explain that in a given population the frequency of occurrence of alleles of a gene is supposed to remain the same through generations ?

OR

Although a prokaryotic cell has no defined nucleus, yet DNA is not scattered throughout the cell. Explain.

9. सं.रा. अमेरिका के अर्काटा, कैलिफोर्निया, के 'अर्काटा कच्छ के मित्र' नामक नागरिक समूह ने एकीकृत अपशिष्ट जल उपचार द्वारा कच्छ भूमि के जल की गुणवत्ता सुधारने में किस प्रकार सहायता की ? चार चरणों में इसकी व्याख्या कीजिए । 2

How did a citizen group called Friends of Arcata Marsh, Arcata, California, USA, help to improve water quality of the marshland using Integrated Waste Water Treatment ? Explain in four steps.



10. बिना-फलीदार स्थलीय फ़सल को उगाने के लिए मिट्टी में नाइट्रोजन की मात्रा में सुधार हेतु आपकी सलाह माँगी गई है ।
- (a) ऐसे दो सूक्ष्मजीवों की अनुशंसा कीजिए जो मिट्टी में नाइट्रोजन का संवर्धन कर सकें ।

(b) फलीदार फ़सलों को मिट्टी के इस प्रकार के संवर्धन की आवश्यकता क्यों नहीं होती ? 2

Your advice is sought to improve the nitrogen content of the soil to be used for cultivation of a non-leguminous terrestrial crop.

(a) Recommend two microbes that can enrich the soil with nitrogen.

(b) Why do leguminous crops not require such enrichment of the soil ?

खण्ड C

SECTION C

11. अनिषेकफलन तथा अनिषेकजनन में विभेद कीजिए । प्रत्येक का एक-एक उदाहरण भी दीजिए । 3
- Differentiate between Parthenocarpy and Parthenogenesis. Give one example of each.

12. चिकित्सा की दृष्टि से सभी युवा माताओं को यह सलाह दी जाती है कि उनके नवजात शिशुओं के लिए स्तनपान सर्वोत्तम है । क्या आप इससे सहमत हैं ? कारण सहित अपने उत्तर की पुष्टि कीजिए । 3

Medically it is advised to all young mothers that breastfeeding is the best for their newborn babies. Do you agree ? Give reasons in support of your answer.

13. पूर्ण विकसित (परिपक्व) मानव शुक्राणु का चित्र बनाइए । इसके तीन भागों को नामांकित कर उनके कार्य लिखिए । 3

Draw a diagram of a mature human sperm. Label any three parts and write their functions.

14. (a) वी.एन.टी.आर. का पूरा नाम लिखिए तथा डी.एन.ए. फिंगरप्रिंटिंग (डी.एन.ए. अंगुलिछापी) में इसकी भूमिका का वर्णन कीजिए ।

(b) डी.एन.ए. अंगुलिछापी तकनीक के कोई दो अनुप्रयोग लिखिए । 3

(a) Expand VNTR and describe its role in DNA fingerprinting.

(b) List any two applications of DNA fingerprinting technique.

15. (a) जैविक किसान रोगों एवं पीड़कों के नियंत्रण के लिए रसायनों की अपेक्षा जैव नियंत्रण को वरीयता देते हैं। औचित्य सिद्ध कीजिए।
- (b) जैव नियंत्रक के रूप में उपयोग किए जाने वाले जीवाणु, कवक एवं कीट का एक-एक उदाहरण दीजिए।
- (a) Organic farmers prefer biological control of diseases and pests to the use of chemicals for the same purpose. Justify.
- (b) Give an example of a bacterium, a fungus and an insect that are used as biocontrol agents.

3

16. पुनर्योगज डी.एन.ए. प्रौद्योगिकी में निम्नलिखित की भूमिका की व्याख्या प्रत्येक के एक-एक उदाहरण की सहायता से कीजिए :

3

- (a) प्रतिबंधन एंजाइम
- (b) प्लाज़्मिड

Explain the roles of the following with the help of an example each in recombinant DNA technology :

- (a) Restriction Enzymes
- (b) Plasmids

17. पशुपालन में बहिःप्रजनन, बहिःसंकरण तथा पार-प्रजनन (संकरण) पद्धतियों की व्याख्या कीजिए।

3

Explain out-breeding, out-crossing and cross-breeding practices in animal husbandry.

18. पक्षियों में 'लिंग-निर्धारण' की क्रियाविधि की व्याख्या कीजिए। मानवों में लिंग-निर्धारण से यह किस प्रकार भिन्न है ?

3

Explain the mechanism of 'sex determination' in birds. How does it differ from that of human beings ?

19. (a) बायोरिएक्टर का विकास जैव-प्रौद्योगिकी में किस प्रकार सहायक हुआ ?
- (b) सर्वाधिक उपयोग में आने वाले बायोरिएक्टर का नाम लिखकर उसकी कार्यविधि का वर्णन कीजिए।
- (a) How has the development of bioreactor helped in biotechnology ?
- (b) Name the most commonly used bioreactor and describe its working.

3



20. तंबाकू के पौधों में *मिल्वाडेगाइन इनकोगनीशिया* के संक्रमण के नियंत्रण में *एग्रोबैक्टीरियम* का संवाहक के रूप में उपयोग किस प्रकार सहायक रहा है ? सही अनुक्रम में व्याख्या कीजिए । 3

How has the use of *Agrobacterium* as vectors helped in controlling *Meloidogyne incognitia* infestation in tobacco plants ? Explain in correct sequence.

21. (a) समरूप तथा समजात संरचनाओं में विभेद कीजिए ।
(b) निम्नलिखित सूची में से समरूप संरचनाओं का चयन करके लिखिए : 3

- (i) तितली एवं पक्षियों के पंख
(ii) कशेरुकी हृदय
(iii) बौगेनविलिया एवं कुकुरबिटा के प्रतान
(iv) शकरकंद और आलू के कंद

- (a) Differentiate between analogous and homologous structures.
(b) Select and write analogous structures from the list given below :
(i) Wings of butterfly and birds
(ii) Vertebrate hearts
(iii) Tendrils of bougainvillea and cucurbita
(iv) Tubers of sweet potato and potato

22. (a) “नॉर्वे की अपेक्षा भारत में पारितंत्र विविधता अधिक है ।” क्या आप इस कथन से सहमत हैं ? कारण बताते हुए अपने उत्तर की पुष्टि कीजिए ।
(b) आनुवंशिक जैव-विविधता तथा जातीय (स्पीशीज़) जैव-विविधता में अंतर लिखिए जो जैविक संगठन के सभी स्तरों में परिलक्षित होते हैं । 3

अथवा

जब किसी नदी में शहरी वाहित मल का विसर्जन किया जाता है, तो नदी के लक्षणों पर पड़ने वाले प्रभाव की व्याख्या कीजिए । 3

- (a) “India has greater ecosystem diversity than Norway.” Do you agree with the statement ? Give reasons in support of your answer.
(b) Write the difference between genetic biodiversity and species biodiversity that exists at all the levels of biological organisation.

OR

Explain the effect on the characteristics of a river when urban sewage is discharged into it.

खण्ड D

SECTION D

23. वायु-प्रदूषण के कारण देश के अनेक शहरों में वायु की गुणवत्ता के गिरते स्तर को लेकर नागरिक बहुत अधिक चिंतित हैं एवं अपने स्वास्थ्य को लेकर परेशान भी हैं। जिन शहरों में वायु की गुणवत्ता अत्यंत खतरनाक स्तर तक पहुँच चुकी है, उनमें चिकित्सकों ने स्वास्थ्य आपात घोषित कर दिया है।
- (a) वायु-प्रदूषण के दो प्रमुख कारकों का उल्लेख कीजिए।
 - (b) वायु-प्रदूषण के कारण पादपों एवं मानवों पर पड़ने वाले कोई दो हानिकारक प्रभाव लिखिए।
 - (c) अपने विद्यालय के ईको-क्लब के कैप्टन की हैसियत से विद्यालय एवं आसपास के क्षेत्रों में वायु-प्रदूषण रोकने के लिए विद्यार्थियों में जागरूकता अभियान के आयोजन के लिए किन्हीं दो कार्यक्रमों का सुझाव दीजिए।

4

Looking at the deteriorating air quality because of air pollution in many cities of the country, the citizens are very much worried and concerned about their health. The doctors have declared health emergency in the cities where the air quality is very severely poor.

- (a) Mention any two major causes of air pollution.
- (b) Write any two harmful effects of air pollution to plants and humans.
- (c) As a captain of your school Eco-club, suggest any two programmes you would plan to organise in the school so as to bring awareness among the students on how to check air pollution in and around the school.



खण्ड E
SECTION E

24. (a) विभिन्न अजैव कारकों के प्रति विभिन्न जन्तुओं की निम्नलिखित अनुक्रियाएँ परिलक्षित होती हैं। प्रत्येक के एक-एक उदाहरण की सहायता से इनका वर्णन कीजिए।
- (i) नियमन करना
 - (ii) संरूपण रखना
 - (iii) प्रवास करना
 - (iv) निलंबित करना
- (b) 80 तितलियों की एक समष्टि में यदि एक सप्ताह में 8 तितलियों की मृत्यु हो जाती है, तो उस अवधि में तितलियों की समष्टि की मृत्यु दर की गणना कीजिए।

5

अथवा

- (a) किसी पारितंत्र में पोषण स्तर क्या होता है ? इसके संदर्भ में 'स्थित शस्य (खड़ी फसल)' का क्या अभिप्राय है ?
- (b) किसी पारितंत्र में 'प्रथम पोषक स्तर' की भूमिका की व्याख्या कीजिए।
- (c) एक प्राकृतिक पारितंत्र में अपरद खाद्य शृंखला, चारण खाद्य शृंखला से किस प्रकार सम्बद्ध है ?
- (a) Following are the responses of different animals to various abiotic factors. Describe each one with the help of an example.
- (i) Regulate
 - (ii) Conform
 - (iii) Migrate
 - (iv) Suspend
- (b) If 8 individuals in a population of 80 butterflies die in a week, calculate the death rate of population of butterflies during that period.

5

OR



- (a) What is a trophic level in an ecosystem ? What is 'standing crop' with reference to it ?
- (b) Explain the role of the 'first trophic level' in an ecosystem.
- (c) How is the detritus food chain connected with the grazing food chain in a natural ecosystem ?

25. (a) पुष्पी पादपों की किन्हीं दो युक्तियों का वर्णन कीजिए जो स्वयुग्मन तथा परनिषेचन को बाधित करती हैं ।
- (b) एक आवृतबीजी के बीजाण्ड की किसी एक सहाय कोशिका में परागनलिका के प्रवेश के उपरांत द्विनिषेचन तक की परिघटनाओं का वर्णन कीजिए ।

5

अथवा

- (a) मानव स्त्रियों में आर्तव चक्र की व्याख्या कीजिए ।
 - (b) मानव स्त्रियों में आर्तव चक्र की वैज्ञानिक समझ गर्भ निरोधक उपाय के रूप में किस प्रकार सहायक हो सकती है ?
- (a) Describe any two devices in a flowering plant which prevent both autogamy and geitonogamy.
- (b) Explain the events upto double fertilisation after the pollen tube enters one of the synergids in an ovule of an angiosperm.

5

OR

- (a) Explain menstrual cycle in human females.
 - (b) How can the scientific understanding of the menstrual cycle of human females help as a contraceptive measure ?
26. (a) उस जीव का वैज्ञानिक नाम लिखिए जिसका उपयोग थॉमस हंट मॉर्गन और उनके साथियों ने अपने प्रयोगों में किया था । जीनों के संदर्भ में सहलग्नता और पुनर्योजन के बीच सहसंबंध में उनके द्वारा किए गए अध्ययन की व्याख्या कीजिए ।
- (b) मॉर्गन के साथ कार्य करते हुए स्टर्टीवेंट ने जीन चित्रण (जीन मैपिंग) की व्याख्या किस प्रकार की ?

5

अथवा



- (a) फ्रैंसिस क्रिक द्वारा प्रतिपादित 'मूल सिद्धान्त' (सेन्ट्रल डोग्मा) लिखिए । क्या इसके कुछ अपवाद भी हैं ? कारण बताते हुए एक उदाहरण की सहायता से अपने उत्तर की पुष्टि कीजिए ।
- (b) 'रूपांतरीय सिद्धान्त' की जैवरासायनिक प्रकृति का निर्धारण किस प्रकार हुआ जो ग्रिफिथ के प्रयोगों द्वारा स्पष्ट नहीं हो पाया था ? समझाइए ।
- (a) Write the scientific name of the organism Thomas Hunt Morgan and his colleagues worked with for their experiments. Explain the correlation between linkage and recombination with respect to genes as studied by them.
- (b) How did Sturtevant explain gene mapping while working with Morgan ?

5

OR

- (a) State the 'Central dogma' as proposed by Francis Crick. Are there any exceptions to it ? Support your answer with a reason and an example.
- (b) Explain how the biochemical characterisation (nature) of 'Transforming Principle' was determined, which was not defined from Griffith's experiments.



Question Paper Code 57/2

SECTION – A

(Q. Nos. 1 - 5 are of one mark each)

1. **Mention the chemical change that proinsulin undergoes, to be able to act as mature insulin.**

Ans. Removal of C - peptide (from pro-insulin)

[1 mark]

2. **Write the names of the following :**

(a) **A 15 mya primate that was ape-like**

(b) **A 2 mya primate that lived in East African grasslands**

Ans. (a) *Dryopithecus* = $\frac{1}{2}$

(b) *Australopithecines* / *Australopithecus* / *Homo habilis* = $\frac{1}{2}$

[1 mark]

3. **Name two diseases whose spread can be controlled by the eradication of *Aedes* mosquitoes.**

Ans. Dengue , Chikunguniya // Yellow Fever / Eastern Equine Encephalitis / West Nile Fever / Zika / Zika Virus Disease (**Any two**) = $\frac{1}{2} + \frac{1}{2}$

[1 mark]

4. **How do cytokine barriers provide innate immunity in humans ?**

Ans. Interferon (proteins) , secreted by virus infected cells (protect non - infected cells from further viral infection) = $\frac{1}{2} + \frac{1}{2}$

[1 mark]

5. **Write the dual purpose served by Deoxyribonucleoside triphosphates in polymerisation.**

Ans. Acts as a substrate , provide energy (from the terminal two phosphates) = $\frac{1}{2} + \frac{1}{2}$

[1 mark]



SECTION B

(Q. Nos. 2 - 10 are of two marks each)

6. (a) Name the source plant of heroin drug. How is it obtained from the plant ?

(b) Write the effects of heroin on the human body.

Ans. (a) - *Papaver somniferum* / Poppy plant = $\frac{1}{2}$

- Extracted from latex of the plant / acetylation of morphine (obtained from the latex of plant) = $\frac{1}{2}$

(b) Depressant, slows down body function = $\frac{1}{2} + \frac{1}{2}$

[1 + 1 = 2 marks]

7. You have obtained a high yielding variety of tomato. Name and explain the procedure that ensures retention of the desired characteristics repeatedly in large populations of future generations of the tomato crop.

Ans. - Tissue culture / micropropagation / somaclonal propagation / apomixis = $\frac{1}{2}$

- Explant / any part of plant taken out and grown (in a test tube / vessel),

- under sterile condition,

- in special nutrient medium (containing carbon source / sucrose, inorganic salt vitamins / amino acids and growth regulator) = $\frac{1}{2} \times 3$

[$\frac{1}{2} + 1\frac{1}{2} = 2$ marks]

8. With the help of an algebraic equation, how did Hardy-Weinberg explain that in a given population the frequency of occurrence of alleles of a gene is supposed to remain the same through generations ?

Ans. In a population of diploid organisms

If frequency of allele A = p and frequency of allele a = q = $\frac{1}{2}$

Expected genotype frequency under random mating are

AA = p^2 (for the AA homozygotes)

aa = q^2 (for the aa homozygotes)



$$Aa = 2pq \text{ (for the Aa heterozygotes)} = \frac{1}{2}$$

(In absence of selection , mutation , genetic drift or other forces allelic frequency p and q are constant through generation)

$$\text{Therefore } p^2 + 2pq + q^2 = 1 = 1$$

[2 marks]

OR

Although a prokaryotic cell has no defined nucleus , yet DNA is not scattered throughout the cell. Explain.

DNA is negatively charged , positively charged proteins , hold it in places , in large loops (in a region termed as nucleoid) = $\frac{1}{2} \times 4$

[2 marks]

9. How did a citizen group called Friends of Arcata Marsh, Arcata, California, USA, help to improve water quality of the marshland using Integrated Waste Water Treatment ? Explain in four steps.

Ans.- Water is treated by conventional method // sedimentation / filtration / chlorination

- Water flows to six connected marshes

- The water in marshes is seeded with appropriate plants / algae / fungi / bacteria

- Which helps to neutralise the pollutants / assimilate the pollutants / absorb pollutants / Remove heavy metals = $\frac{1}{2} \times 4$

[2 marks]

10. Your advice is sought to improve the nitrogen content of the soil to be used for cultivation of a non-leguminous terrestrial crop.

(a) Recommend two microbes that can enrich the soil with nitrogen.

(b) Why do leguminous crops not require such enrichment of the soil ?

Ans. (a) *Azospirillum* / *Azotobacter* / *Anabaena* / *Nostoc* / *Oscillatoria* / *Frankia* (Any two correct names of microbes) = $\frac{1}{2} + \frac{1}{2}$

(If cyanobacteria mentioned = $\frac{1}{2}$, but if along with cyanobacteria *Anabaena* / *Nostoc* / *Oscillatoria* mentioned then **No mark** on cyanobacteria)

- (b) They can fix atmospheric nitrogen, due to presence of *Rhizobium* / N_2 fixing bacteria in their root nodules = $\frac{1}{2} + \frac{1}{2}$

[1 + 1 = 2 marks]

SECTION C

(Q. Nos. 11 - 22 are of three marks each)

11. Differentiate between Parthenocarpy and Parthenogenesis. Give one example of each.

Ans.	<u>Parthenocarpy</u>	<u>Parthenogenesis</u>
	- Formation of fruit without fertilization = 1	- New organism develops without fertilization = 1
	- e.g. banana / grapes / any other correct example = $\frac{1}{2}$	- e.g. Drones / male honey bee / turkey / rotifers / some lizards / any other correct example = $\frac{1}{2}$

[1 $\frac{1}{2}$ + 1 $\frac{1}{2}$ = 3 marks]

12. Medically it is advised to all young mothers that breastfeeding is the best for their newborn babies. Do you agree? Give reasons in support of your answer.

Ans. Yes = 1 ,

provides nutrition (calcium, fats, lactose) / provides (passive) immunity / provides antibodies / Ig A (*Any two*) = 1 + 1

[1 + 2 = 3 marks]

13. Draw a diagram of a mature human sperm. Label any three parts and write their functions.



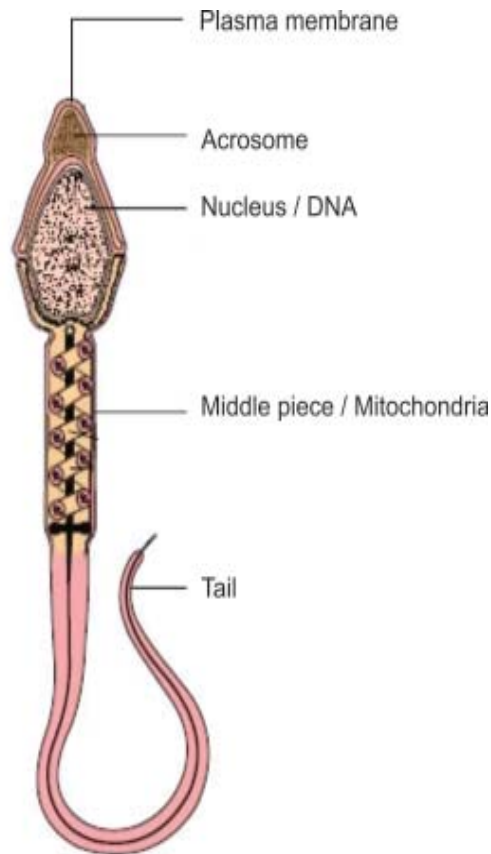

(Any three labelling) = $\frac{1}{2} \times 3$

Plasma membrane - Envelope of the sperm

Acrosome - Filled with enzyme that help fertilization of ovum

Mitochondria - Energy source for swimming

Middle Piece - Possess mitochondria which is the energy source for swimming

Tail - For movement of sperm

Nucleus - Containing chromosomal material

(Functions of the parts labelled) = $\frac{1}{2} \times 3$

[$1\frac{1}{2} + 1\frac{1}{2} = 3$ marks]

14. (a) **Expand VNTR and describe its role in DNA fingerprinting.**
(b) **List any two applications of DNA fingerprinting technique.**

Ans. (a) VNTR - Variable Number of Tandem Repeat(s) = $\frac{1}{2}$

- used as a probe (because of its high degree of polymorphism) = $\frac{1}{2}$

- (b) Forensic science / criminal investigation (any point related to forensic science) / determine population and genetic diversities / paternity testing / maternity testing / study of evolutionary biology (*Any two*) = 1 + 1

[1 + 2 = 3 marks]

15. (a) **Organic farmers prefer biological control of diseases and pests to the use of chemicals for the same purpose. Justify.**

- (b) **Give an example of a bacterium, a fungus and an insect that are used as biocontrol agents.**

Ans. (a) - Reduces dependence on toxic chemicals

- Protects our ecosystem or environment

- Protects and conserves non-target organisms / they are species - specific

- These chemicals being non-biodegradable may pollute the environment permanently

- These chemicals being non-biodegradable may cause biomagnification

(*Any three*) = $\frac{1}{2} \times 3$

- (b) Bacteria – *Bacillus thuringiensis* = $\frac{1}{2}$

Fungus – *Trichoderma* = $\frac{1}{2}$

Insect – Ladybird / Dragonfly / Moth or any other correct example = $\frac{1}{2}$

[$1\frac{1}{2} + 1\frac{1}{2} = 3$ marks]

16. **Explain the roles of the following with the help of an example each in recombinant DNA technology:**

- (a) **Restriction Enzymes**

- (b) **Plasmids**



Ans. (a) It recognises a specific sequence of base pairs / pallindromes, and cuts the DNA strand at a specific site = $\frac{1}{2} + \frac{1}{2}$

eg. EcoRI / Hind II or any other correct example = $\frac{1}{2}$

(b) Act as vectors / cloning of desired alien gene / foreign gene = 1

eg. pBR322 / plasmid of *Salmonella* / plasmid of *Agrobacterium* / Ti Plasmid / Tumour inducing Plasmid = $\frac{1}{2}$

[$1\frac{1}{2} + 1\frac{1}{2} = 3$ marks]

17. Explain out-breeding, out-crossing and cross-breeding practices in animal husbandry.

Out breeding – Breeding of unrelated animals (which may be between individual of same breed or between individuals of different species) = 1

Out crossing – (a kind of out breeding) Mating of animals within the same breed but having no common ancestors on either side of their pedigree upto 4 – 6 generations = 1

Cross breeding – (another type of out breeding) Superior males of one breed are mated with superior females of another breed = 1

[$1+1+1 = 3$ marks]

18. Explain the mechanism of ‘sex determination’ in birds. How does it differ from that of human beings ?

Ans. In birds ;

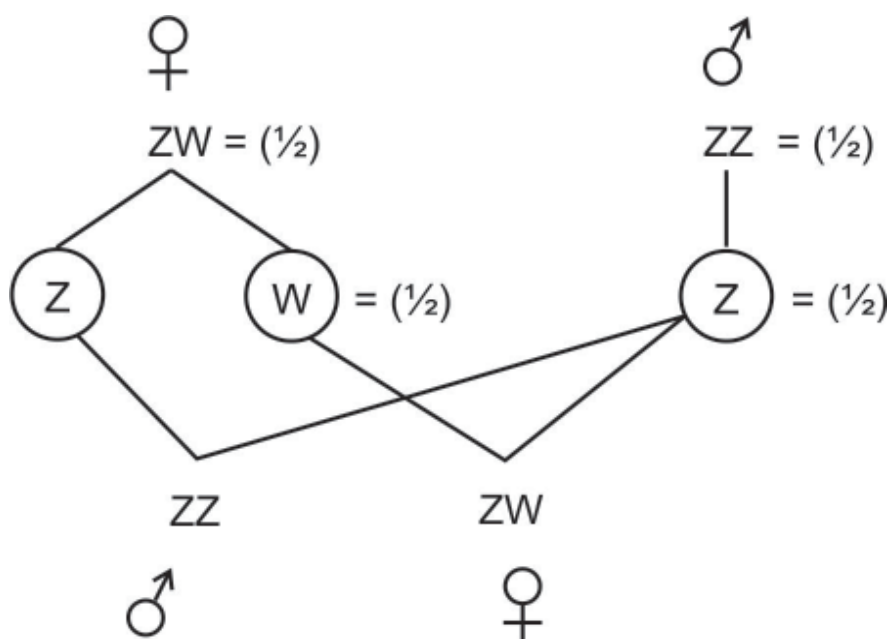

Birds : female heterogamety / female produces (Z) type and (W) type of gametes = $\frac{1}{2}$

Humans : male heterogamety / male produces (X) type and (Y) type of gametes = $\frac{1}{2}$

[2 + 1 = 3 marks]

19. (a) **How has the development of bioreactor helped in biotechnology ?**

(b) **Name the most commonly used bioreactor and describe its working.**

Ans. (a) Larger biomass / large volume of culture can be processed leading to higher yields of desired specific products (protein / enzymes) , under controlled condition = $\frac{1}{2}$ + $\frac{1}{2}$

(b) Stirring type = $\frac{1}{2}$

- Mixing of reactor contents evenly (with agitator system or a stirrer) = $\frac{1}{2}$
- Facilitates oxygen availability = $\frac{1}{2}$
- Temperature / pH / foam control // under optimum conditions = $\frac{1}{2}$

[1 + 2 = 3 marks]

20. **How has the use of *Agrobacterium* as vectors helped in controlling *Meloidogyne incognita* infestation in tobacco plants ? Explain in correct sequence.**

- Ans. - Using *Agrobacterium* vector nematode specific genes introduced into host plant
- Sense and antisense strands of mRNA are produced
 - ds RNA is formed
 - ds RNA initiates RNAi
 - Prevents translation of mRNA / silencing of mRNA of parasite / nematode
 - Parasite will not survive

[$\frac{1}{2} \times 6 = 3$ marks]

21. (a) **Differentiate between analogous and homologous structures.**

(b) **Select and write analogous structures from the list given below :**

- (i) Wings of butterfly and birds
- (ii) Vertebrate hearts
- (iii) Tendrils of bougainvillea and cucurbita
- (iv) Tubers of sweet potato and potato

Ans. (a) Analogous - Anatomically not similar though perform similar functions / are a result of convergent evolution = 1

Homologous - Anatomically similar (but perform different functions) / are a result of divergent evolution = 1

(b) Option (i) Wings of butterfly and birds / (iv) Tubers of sweet potato and potato (*Any one*) = 1

[2 + 1 = 3 marks]

22. (a) **“India has greater ecosystem diversity than Norway.” Do you agree with the statement ? Give reasons in support of your answer.**

(b) **Write the difference between genetic biodiversity and species biodiversity that exists at all the levels of biological organisation.**

Ans. (a) Yes = ½

India / tropical region

Norway / temperate region

- are less seasonal

- more seasonal /

/ more constant / more predictable

/ less constant / less predictable

- promote niche specialisation

- do not promote niche specialisation

leading to greater bio-diversity

leading to low bio-diversity

- Species diversity increases as we move towards equator

- Species diversity decreases as we move away from equator

- More number of species exist

- Less number of species exist

(*Any one*) = ½

(b) Genetic diversity - Diversity / variation within a species over its distributional range / same explained with the help of a correct example = 1



Species diversity - Diversity / variation at a species level / same explained with the help of a correct example = 1

[1 + 2 = 3 marks]

OR

Explain the effect on the characteristics of a river when urban sewage is discharged into it.

- Ans. - Rise in organic matter , leads to increased microbial activity / growth of microbes = $\frac{1}{2} + \frac{1}{2}$
- It results in decrease in dissolved oxygen / rise in BOD / rise in Biochemical Oxygen Demand = 1
 - Leads to fish mortality / algal bloom / colour change / foul odour / increase in toxicity (**Any two**) = $\frac{1}{2} + \frac{1}{2}$

[1 + 1 + 1 = 3 marks]

SECTION D

(Q. Nos. 23 is of four marks)

23. Looking at the deteriorating air quality because of air pollution in many cities of the country, the citizens are very much worried and concerned about their health. The doctors have declared health emergency in the cities where the air quality is very severely poor .

- (a) Mention any two major causes of air pollution.**
- (b) Write any two harmful effects of air pollution to plants and humans.**
- (c) As a captain of your school Eco-club, suggest any two programmes you would plan to organise in the school so as to bring awareness among the students on how to check air pollution in and around the school.**

Ans. (a) Vehicular discharge / smoke from industries / burning of agricultural wastes / smoke from incinerator / dust / smoke from thermal plants or any other correct cause

(Any two) = $\frac{1}{2} + \frac{1}{2}$

- (b) Reduces growth of plants / reduces yields of crops / premature death of plants / respiratory problems / acid rain / any other relevant point (**Any two - one from plant and one from human**) = 1 + 1



- (c) Plantation drive / awareness programmes through posters / nukkad natak / film show / rallies / debates or any other (**Any two**) = 1 + 1

[1 + 1 + 2 = 4 marks]

SECTION E

(Q. Nos. 24 - 26 are of five marks each)

24. (a) Following are the responses of different animals to various abiotic factors. Describe each one with the help of an example.
- (i) Regulate
 - (ii) Conform
 - (iii) Migrate
 - (iv) Suspend
- (b) If 8 individuals in a population of 80 butterflies die in a week, calculate the death rate of population of butterflies during that period.

- Ans. (a) (i) Regulate - Maintain constant internal temperature / osmotic concentration / homeostasis = $\frac{1}{2}$
- e.g. birds / mammals = $\frac{1}{2}$
- (ii) Conform - Do not maintain constant internal temperature / osmotic concentration / No homeostasis = $\frac{1}{2}$
- e.g. any one example of animal other than birds and mammals = $\frac{1}{2}$
- (iii) Migrate - Temporary movement of organisms from the stressful of habitats to hospitable areas and return when stressful period is over = $\frac{1}{2}$
- e.g. birds from Siberia / or any other correct example = $\frac{1}{2}$
- (iv) Suspend - Reducing / minimising the metabolic activities during unfavourable conditions = $\frac{1}{2}$
- e.g. Polar bear / amphibian / snails / fish / any other example of animals = $\frac{1}{2}$

(b) Death rate = $\frac{8}{80} = 0.1$, individuals per butterfly per week = $\frac{1}{2} + \frac{1}{2}$

[4 + 1 = 5 marks]



OR

- (a) What is a trophic level in an ecosystem ? What is 'standing crop' with reference to it ?
- (b) Explain the role of the 'first trophic level' in an ecosystem.
- (c) How is the detritus food chain connected with the grazing food chain in a natural ecosystem ?

- Ans. (a) Specific place of an organism in a food chain , mass of living material (biomass) at each trophic level at a particular time = 1 + 1
- (b) First trophic level has producers / autotrophs , which trap solar energy / to produce food (photosynthesis) = 1 + 1
- (c) Organisms of the Detritus food chain (DFC) are the prey to the Grazing food chain (GFC) organism , the dead remains of GFC are decomposed into simple inorganic materials which are absorbed by DFC organisms = $\frac{1}{2} + \frac{1}{2}$

[2 + 2 + 1 = 5 marks]

25. (a) Describe any two devices in a flowering plant which prevent both autogamy and geitonogamy.
- (b) Explain the events upto double fertilisation after the pollen tube enters one of the synergids in an ovule of an angiosperm.

- Ans. (a) - Dioecy / production of unisexual flowers (in different plants)
- Self incompatibility = 1 + 1
- (b) - Pollen tube releases 2 male gametes in the cytoplasm of synergid
- One male gamete fuses with egg cell / syngamy , resulting in diploid zygote
- Other male gamete fuses with polar nuclei / triple fusion , to form triploid PEN (Primary Endosperm Nucleus) / PEC (Primary Endosperm Cell) = 1 × 3

[2 + 3 = 5 marks]

OR

- (a) Explain menstrual cycle in human females.
- (b) How can the scientific understanding of the menstrual cycle of human females help as a contraceptive measure ?



- Ans. (a) - Menstrual Phase - Menstrual flow occurs / due to breakdown of endometrial lining of uterus , when fertilization does not occur
- Follicular Phase - Primary follicles grow into mature graafian follicles and endometrium regenerates through proliferation , changes induced by pituitary and ovarian hormones
 - Ovulatory Phase - LH surge , induces rupture of graafian follicle and release of secondary oocyte / ovum during middle of cycle (i.e. 14th day)
 - Luteal phase - Ruptured graafian follicle transforms into corpus luteum which secrete large amount of progesteron , essential for maintaining endometrium = 1×4
- (b) Because ovulation occurs during mid cycle chances of fertilisation are very high so , couples should abstain from coitus between day 10 - 17 = $\frac{1}{2} + \frac{1}{2}$

26. (a) **Write the scientific name of the organism Thomas Hunt Morgan and his colleagues worked with for their experiments. Explain the correlation between linkage and recombination with respect to genes as studied by them.**
- (b) **How did Sturtevant explain gene mapping while working with Morgan ?**

Ans. (a) *Drosophila melanogaster* = 1

They observed that two genes (located closely on a chromosome) did not segregate independently of each other (F_2 ratio deviated significantly from $9 : 3 : 3 : 1$) = $\frac{1}{2}$

Tightly linked genes tend to show fewer (lesser) recombinant frequency of parental traits / show higher (more) frequency of parental type = $\frac{1}{2}$

Loosely linked genes show higher percentage (more) of recombinant frequency of parental traits / lower frequency percentage of parental type = $\frac{1}{2}$

Genes present on same chromosome are said to be linked and the recombinant frequency depends on their relative distance on the chromosome = $\frac{1}{2}$

- (b) He used the frequency of recombination between gene pairs on the same chromosome , as a measure of the distance between genes and mapped their position on the chromosome = 1 + 1

[3 + 2 = 5 marks]

OR

- (a) **State the ‘Central dogma’ as proposed by Francis Crick. Are there any exceptions to it ? Support your answer with a reason and an example.**



- (b) Explain how the biochemical characterisation (nature) of 'Transforming Principle' was determined, which was not defined from Griffith's experiments.

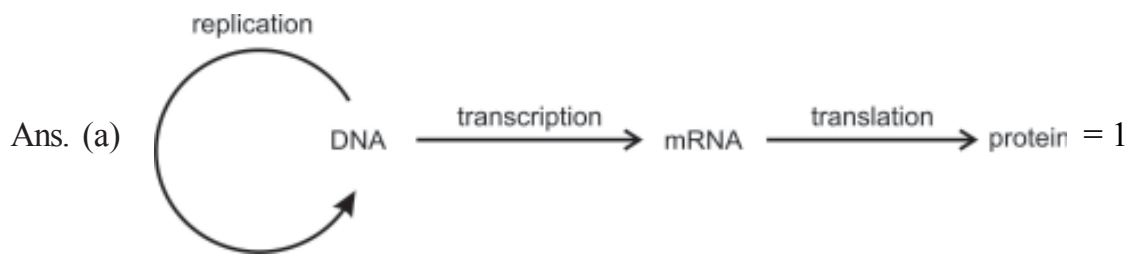

Yes, in some viruses flow of information is in reverse direction / reverse transcription = $\frac{1}{2} + \frac{1}{2}$

e.g. Any Retrovirus / HIV = $\frac{1}{2}$

- (b) Protein and DNA and RNA were purified from heat killed S strain / smooth *Streptococcus / Diplococcus pneumoniae* = $\frac{1}{2}$

Protein + Protease \rightarrow transformation occurred (R cell to S type) = $\frac{1}{2}$

RNA + RNA ase \rightarrow transformation occurred (R cell to S type) = $\frac{1}{2}$

DNA + DNA ase \rightarrow transformation inhibited = $\frac{1}{2}$

Hence DNA alone is the transforming material = $\frac{1}{2}$

[2 + 3 = 5 marks]

